

Torque Limiting Couplings. SafeSet, SmartSet and AutoSet



Contents

Product Overview	6
SafeSet	8
ST-B Series for Plain Shafts	12
ST-KB Series for Keywayed Shafts	13
SR-P Series for Flange to Flange Connections.....	14
SR-N Series for Shaft to Flange Connections	15
SR-F Series for Shaft to Flange Connections	16
SR-F Series for Heavy Duty Shaft to Flange Connections	17
SR-C Series for Heavy Duty Compact Design	18
SR-F Series for Shaft to Flange Connections	19
SR-PF Series for Flange to Flange Connections.....	20
Special Adaptions.....	21
SmartSet	22
SM-F Series for Shaft to Flange Connections	23
SM-PF Series for Flange to Flange Connections	23
AutoSet	24
Customized AutoSet for Shaft to Flange and Flange to Flange Connection	26
SA-I Series for Integrated Custom Solutions	27
Equipment for Easy Handling	28

Protect Your Driveline and Maximize Production. For Years to Come

The outstanding precision and reliability of Voith torque limiting couplings ensures smooth operation and less wear and tear – during the entire life span of your driveline.

Drivelines in rotating equipment are long term investments, worth protecting. Every minute of downtime caused by overload, is a loss in production. Voith torque limiting couplings secure your driveline against torque overloads. Your equipment can safely operate at a maximum level. This makes a difference to your overall economy.





Optimizing Your Driveline

Our extensive industry application knowledge helps your equipment achieve its highest performance level.

Based on the unique requirements of each specific application, our team of specialists take care of the whole process, to find the optimal torque limiting solution for the driveline intended.

Our engineers use their extensive knowledge and system expertise to optimize your driveline. During the design stage Voith performs advanced driveline analysis, to evaluate the

dynamic torque response. Specialist technicians can use this data to position the torque limiting coupling in the optimal location.

To ensure your equipment reaches its maximum potential, a preset torque level is set once the coupling is in place. This gives the driveline maximum protection and enables a higher production level.



- 1 Gas turbine
- 2 Rolling Mill
- 3 Cone crusher
- 4 Tugboat

Worldwide Industries

Industry	Applications	Challenges	Solution with Torque Limiting Couplings
Mining	Crushers and Grinders Conveyors and Excavators TBM's	Harsh environments and heavy duty drivelines that can become blocked or suffer torque overloading	Protects the machinery from damage by releasing or slipping at a precise set torque which minimizes operating downtime and increase production uptime
Marine	Thrusters and Waterjets Harbour and deck machinery	Torque overloads brought by debris in the water can mean days in dry dock and cause damage to the propulsion driveline	Protect drivelines and machinery from overload and ensure a smooth, reliable propulsion which minimizes operating downtime and increase production uptime
Steel	Levellers Rolling and Steckel mills Plate and Strip mills	High and heavy loads put intense performance demands on the driveline, which can lead to torque overloading and slippage marks	Avoids overload situations, reduces wear on the rolls and protects the driveline which minimizes operating downtime and increase production uptime
Recycling	Shredders and Crushers	Overloads, vibrations and torque shocks can occur when crushing and shredding large, strong materials	Protect the motors and driveline and provide a steady power supply
Energy	Gas turbines Compressors	Unpredictability when generating energy can mean short circuiting, electrical faults, overloading, torsional vibrations, voltage drops or malsynchronization	Limits torsional vibrations, protects the driveline and provides a reliable release torque
Rail	High speed trains	A broken cardan shaft due to excessive torque could fall down on the track and cause major danger to passengers on or outside the train	Prevents excessive torque and protects the passengers from danger

Product Overview

Voith torque limiting couplings are used in many applications in industries worldwide. SafeSet, SmartSet and AutoSet ensure safe operation of the driveline, by releasing or slipping at a very precise torque level. This protects driveline equipment and smoothen production.

Coupling and function

Features

Coupling and function		Features
SafeSet Torque limiting coupling with instant release	SafeSet SmartSet AutoSet	Accurate release torque
		Compact and flexible design
		Instant torque limitation in overload situations
		Adjustable release torque
		Back-lash free power transmission
		Set torque remains constant over time
		Quick and easy resetting
SmartSet Process improving coupling with controlled slip		Limitation of short peaks without release
		Automatic resetting of slip angle
		Complete disengagement during a long peak event
AutoSet Process improving coupling with controlled slip and automatic reset		Automatically resets itself to the preset torque limit after a longer overload/complete blockage



SafeSet SR-F 356



SmartSet SM-F 305



AutoSet SA-F 360

Benefits

Increases production uptime

due to precise point of release that gives higher safety margins in the production level, higher out put of the driveline and less repair of drive equipment

High utilization of investment

due to optimized driveline design- no need of changes in your existing driveline and can be positioned anywhere to maximize the driveline

Protects your driveline from expensive standstill costs

due to minimized risk of overload and minimized delay time in production

Minimizes additional cost in the event of a upgrade of the driveline

due to adaptability to the existing driveline design and specific application requirements

Minimizes cost of repair

due to protection against wear on other parts in the driveline

Continous production process

due to no unwanted releases and reduced repair time

Minimizes standstill and downtime

Improves production uptime

due to no resetting needed for short peak event

Lower maintenance cost

due to no manual resetting needed

Less investment cost

due to no additional equipment needed

Improves production uptime

due to continous operation even during an overload event

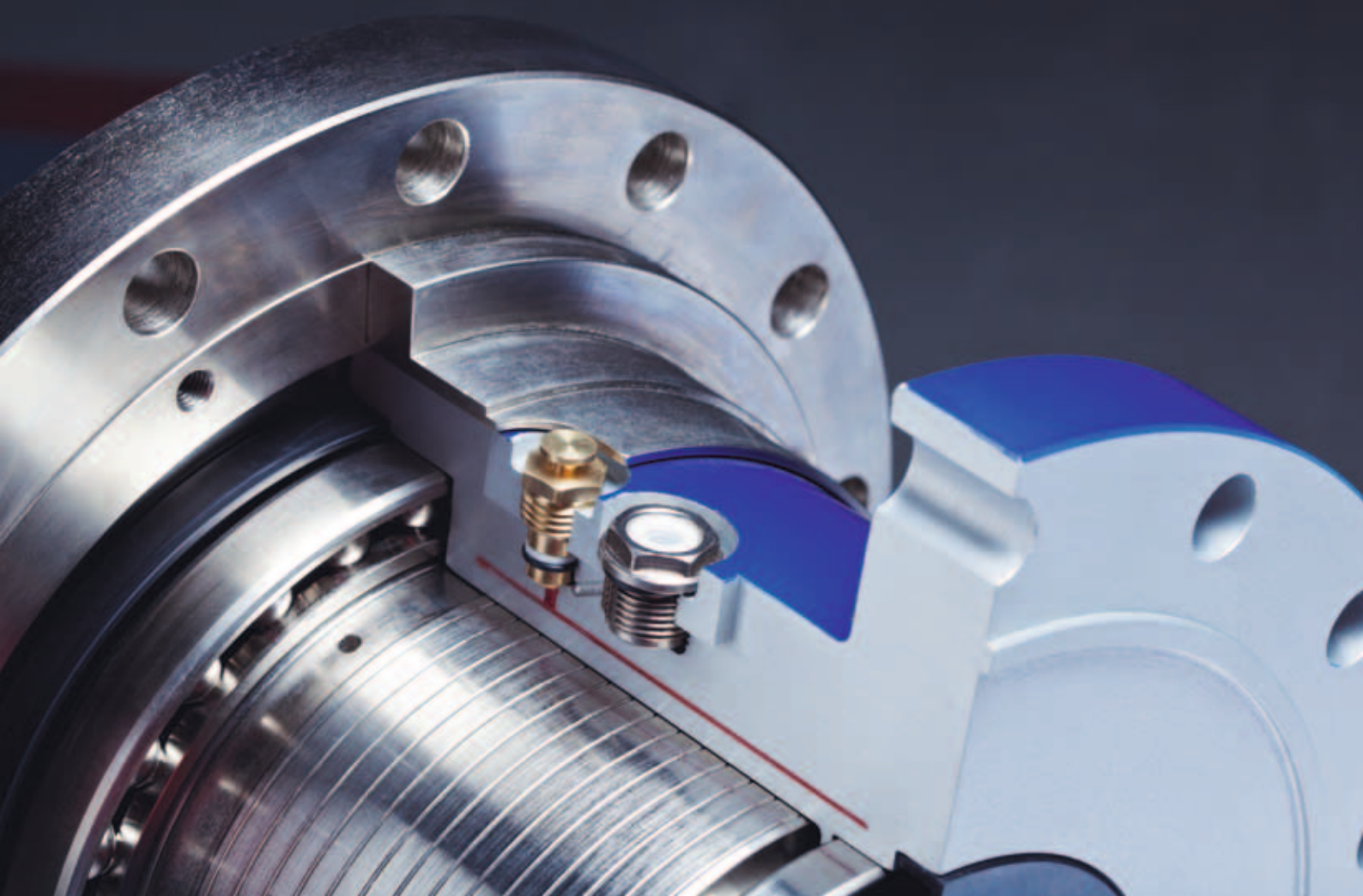

SafeSet – Torque Limiting Coupling with Instant Release

Operation

The SafeSet principle is simple: friction and flexibility. No material fatigue, a constant torque transmission and adaptability. The SafeSet coupling includes a twin-walled hollow sleeve. Friction is generated upon expansion by pressurized hydraulic oil. The integrated shear tube holds pressure to ensure a constant but easy adaptable torque transmission. In an overload situation the SafeSet slips and the shear tube shears off. Oil pressure drops and the frictional surfaces separate. Then the SafeSet rotates on the bearings without transmitting any torque.

Torque capacity available between 1 and 20 000 kNm



Voith torque limiting couplings are customized and can be manufactured in a various ranges and friction diameter.

Picture illustrates a SafeSet SR-F 1 300 with a friction diameter of 1 300 mm, weight of 17 000 kg, maximum speed 25 rpm, and a maximum release torque of 15 000 kNm.

SafeSet being pressurized

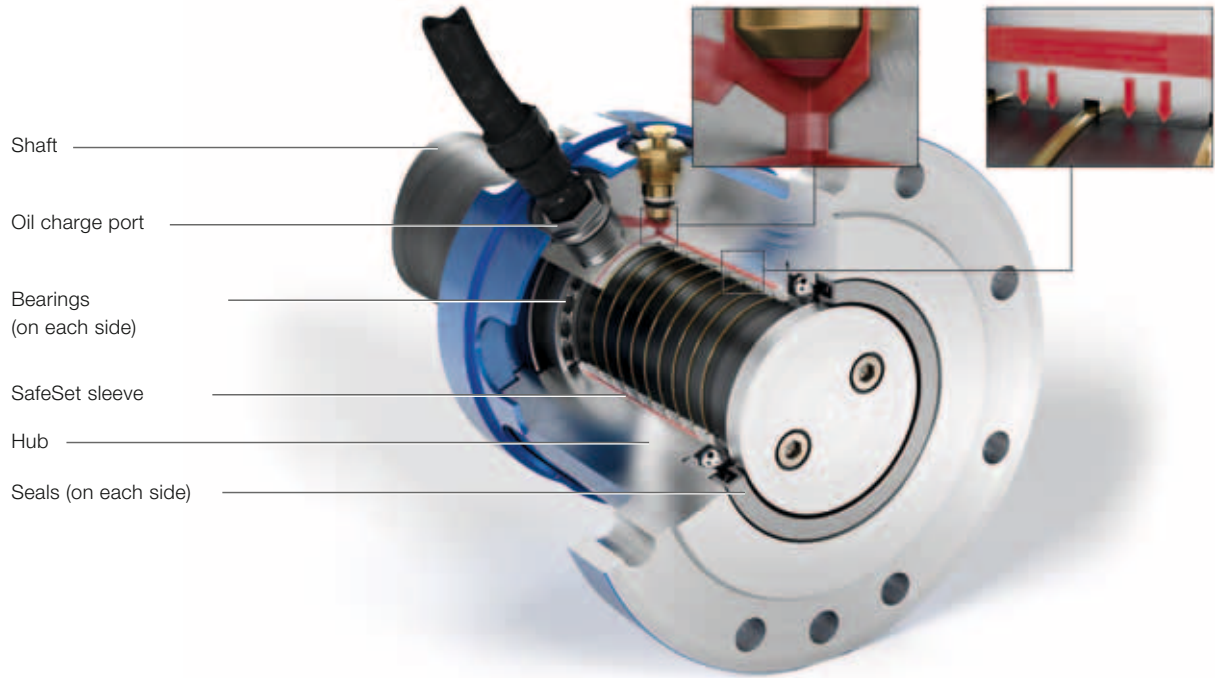

SafeSet following a release

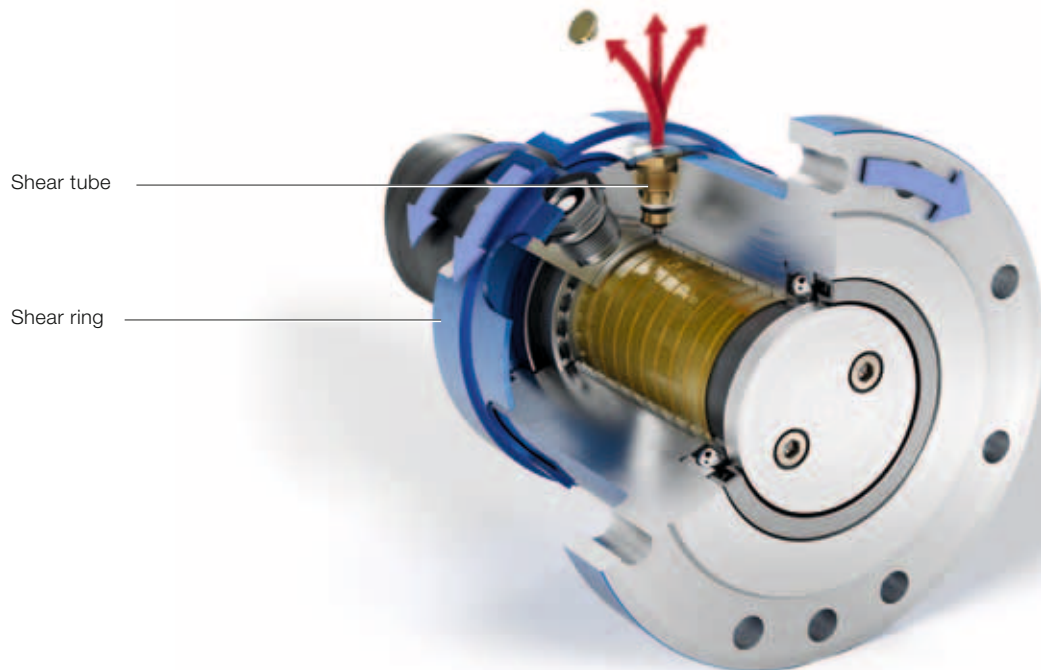

Shear tube illustration

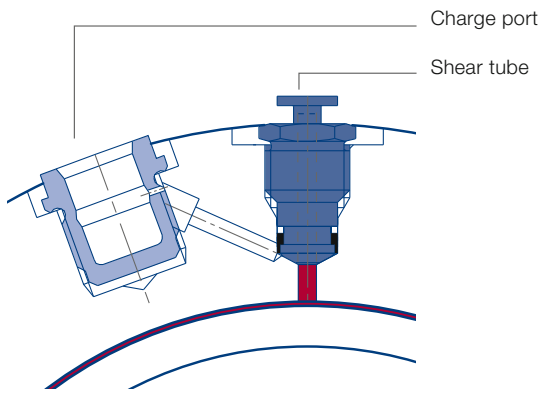

Calibration curve (Calibration diagram)

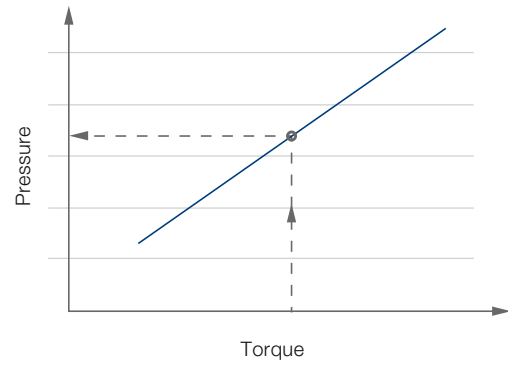

Fatigue curve (S-N curve)

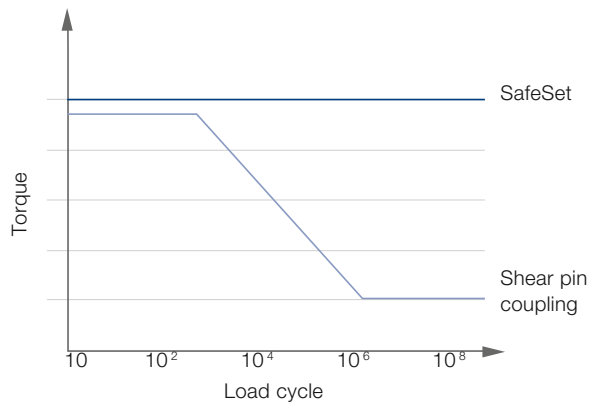

Typical release curve

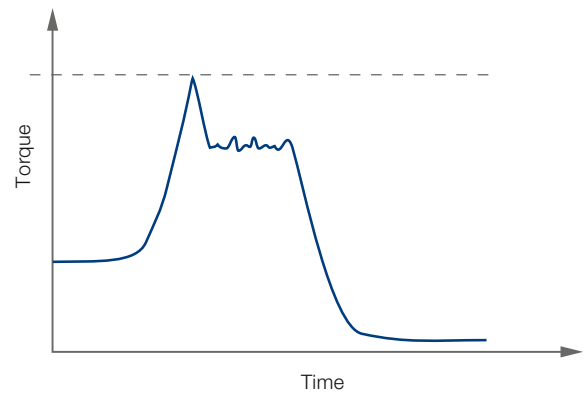

ST-B Series for Plain Shafts

For installation between a plain shaft and a hub.

Size ST-B	M_A [kNm]	d_1	d_2	d_3	d_4	L_1	L_2	L_3	M	m [kg]	J [kgm ²]
60	1.8 – 3.6	60	75	40	132	137	128	83	M6	5	0.01
70	2.7 – 5.4	70	90	50	144	150	140.5	92	M6	6.8	0.02
80	4 – 8	80	100	50	153	166	156.5	108	M6	7.8	0.03
90	5.5 – 11	90	110	65	164	184	170	123	M8	9.4	0.04
100	7.5 – 15	100	125	70	179	206	191	133	M8	13.5	0.06
110	9 – 18	110	140	80	197	208	193	137	M8	17	0.09
120	14 – 28	120	150	90	205	237	221	161	M8	20	0.12
130	18 – 36	130	160	100	214	250	234	174	M8	22	0.14
140	22 – 44	140	170	105	224	261	245	183	M10	24	0.18
150	27 – 54	150	180	115	234	275	259	195	M10	27	0.22
160	34 – 68	160	200	120	249	300	284	215	M10	37	0.34
170	39 – 78	170	210	130	254	300	282	213	M10	38	0.37
180	44 – 88	180	225	135	316	300	281	213	M10	45	0.49
190	58 – 116	190	240	145	316	350	332	260	M10	56	0.68
200	65 – 130	200	250	150	316	350	332	260	M10	61	0.81
220	82 – 164	220	270	175	316	350	332	260	M10	65	1

The coupling is a tailor-made product. The table shows some examples.

M_A : release torque – adjustment range

m: mass (weight)

J: mass moment of inertia

Dimensions in mm.

SafeSet ST-B

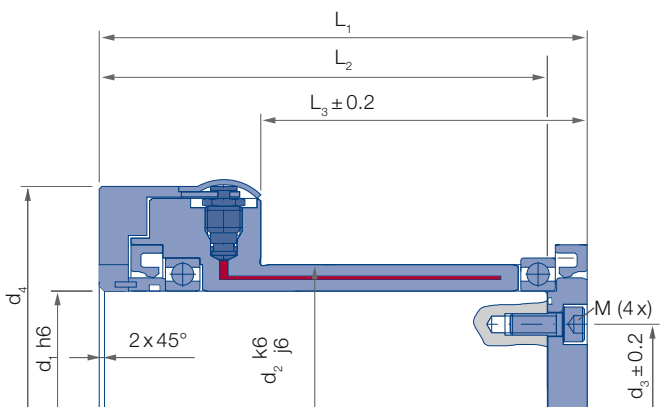

ST-B series, in combination with a flexible rubber coupling

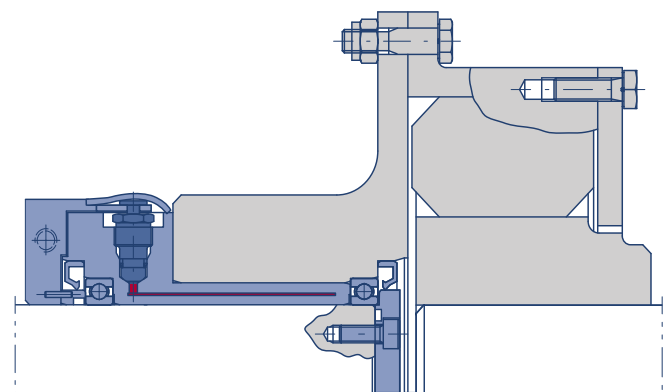

ST-KB Series for Keywayed Shafts

For installation between a keywayed shaft, and hub.
The friction surface is between the coupling and the hub.

Size ST-KB	M_A [kNm]	d_1^1	d_1^2	d_2	d_3	d_4	L_1	L_2	M	m [kg]	J [kgm ²]
60	1 – 2	41	44	60	123	134	112	73	M6	4.2	0.01
70	1.5 – 3	48	52	70	133	143	119	80	M6	5.1	0.01
80	2.1 – 4.2	55	62	80	141	152	124	85	M6	6.1	0.01
90	3 – 6	65	69	90	148	159	136	93	M6	7.5	0.02
100	3.9 – 7.8	71	77	100	158	169	140	97	M6	8.4	0.02
108	5 – 10	76	85	107.95	166	177	146	103	M6	9.9	0.03
120	7 – 14	86	95	120.65	174	185	160	117	M6	12	0.04
127	9 – 17	92	99	127	181	192	172	128	M6	14	0.05
140	10 – 20	100	110	139.7	193	204	176	132	M6	17	0.07
152	13 – 26	110	120	152.4	206	221	175	134	M8	18	0.09
165	17 – 34	120	130	165.1	220	233	194	150	M8	23	0.13
178	23 – 46	130	141	177.8	229	243	219	175	M8	29	0.18
203	35 – 70	150	161	203.2	262	277	253	210	M8	42	0.32
228	50 – 100	168	181	228.6	295	310	281	235	M8	63	0.62
254	70 – 140	193	209	254	318	333	303	256	M8	80	1
280	90 – 180	208	228	280	390	410	311	259	M8	96	1.4

The coupling is a tailor-made product. The table shows some examples.

M_A : release torque – adjustment range

m: mass (weight)

J: mass moment of inertia

d_1^1 : Maximum shaft diameter with key according to DIN 6885; d_1^2 : Maximum shaft diameter with lowest possible key

Dimensions in mm.

SafeSet ST-KB

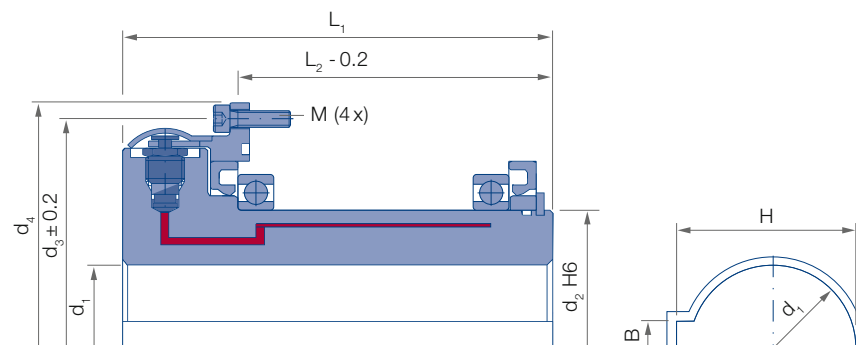

ST-KB series, integrated into the gear hub of a gear coupling

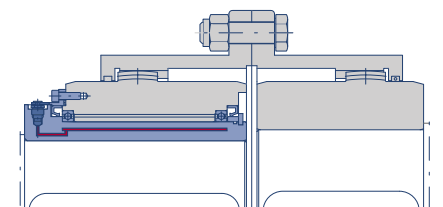

SR-P Series for Flange to Flange Connections

Compact design, with connection flanges at each end, often in combination with a flexible coupling, such as a gear coupling.

Size SR-P	M_A [kNm]	d_1	d_2	d_3	d_4	d_5	z	L_1	L_2	L_3	L_4	m [kg]	J [kgm ²]
60	1.6 – 3.2	94	122	152	96	11	8	115	19	2	15	11	0.02
80	2.9 – 5.8	115	150	178	122	13	6	113	19	2	18	15	0.05
100	5.4 – 10.8	140	184	213	150	17	6	135	22	2	22	25	0.11
110	8.2 – 16.4	163	208	240	174	17	8	161	22	2	–	36	0.19
130	12.6 – 25.2	188	242	280	200	21	8	173	28	2	–	53	0.38
160	20.5 – 41	222	280	318	234	21	8	193	28	2	–	76	0.72
190	28 – 56	245	305	347	262	21	10	199	28	3	–	99	1.1
203	39 – 78	273	345	390	306	21	10	206	38	3	–	138	2.1
228	58 – 116	310	368	425	332	21	14	240	38	3	–	185	3.2
254	111 – 222	331	406	457	355	25	14	330	26	4	–	280	5.1
300	142 – 284	371	460	527	404	25	16	309	28	6	–	400	11
356	244 – 488	451	530	591	472	32	14	385	33	6	–	670	24
406	290 – 580	483	580	640	522	32	18	387	38	6	–	800	34

The coupling is a tailor-made product. The table shows some examples.

M_A : release torque – adjustment range

m : mass (weight)

J : mass moment of inertia

Dimensions in mm.

SafeSet SR-P

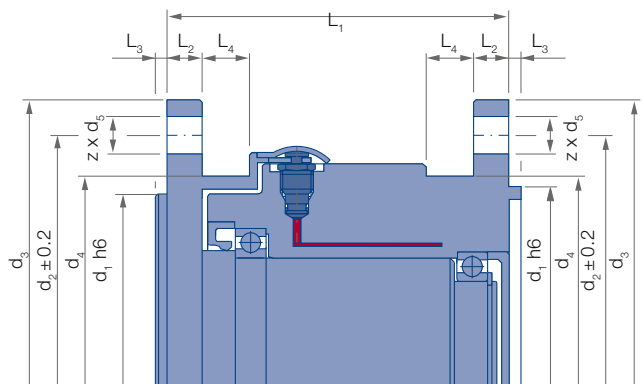

SR-P in between two gear coupling halves

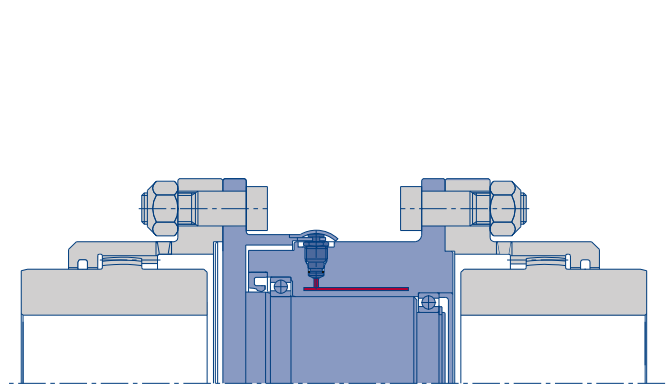

SR-N Series for Shaft to Flange Connections

For installation between a plain shaft and a flange connection, such as universal joint shaft, elastic coupling, steel membrane coupling etc.

Size SR-N	M_A [kNm]	d_1	d_2	d_3	d_4	d_5	d_6	d_7	z	L_1	L_2	L_3	L_4	M	m [kg]	J [kgm ²]
60	1.8 – 3.6	60	180	110	155.5	14	40	132	8	136	12	2.3	128	M6	12	0.03
70	3 – 6	70	180	110	155.5	14	50	144	8	150	12	2.3	140	M6	13	0.04
80	3.9 – 7.8	80	225	140	196	16	50	153	8	166	15	4	156.5	M6	20	0.09
90	5 – 10	90	225	140	196	16	65	164	8	184	15	4	171	M8	27	0.11
100	7.5 – 15	100	250	140	218	18	75	179	8	203	18	5	190	M10	30	0.17

The coupling is a tailor-made product. The table shows some examples.

Other sizes and features are available upon request. Above size 120 the type SR-F is recommended.

M_A : release torque – adjustment range

m : mass (weight)

J : mass moment of inertia

Dimensions in mm.

SafeSet SR-N

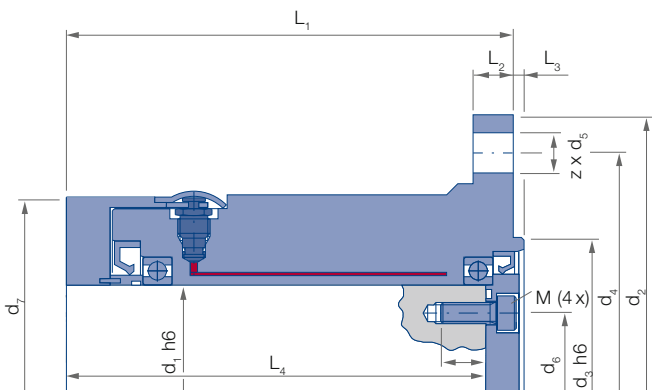

SR-N series, keyway sleeve connected to gear couplings with spacer shaft

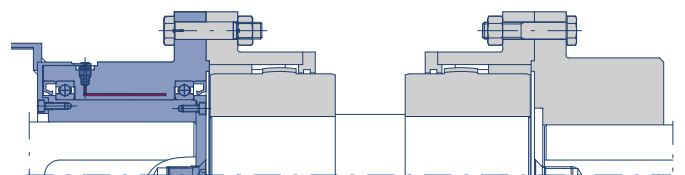

SR-F Series for Shaft to Flange Connections

For installation between a plain shaft and a flange connection, such as universal joint shaft, elastic coupling, steel membrane coupling etc.

Size SR-F	M_A [kNm]	d_1	d_2	d_3	d_4	d_5	d_6	d_7	z	L_1	L_2	L_3	L_4	M	m [kg]	J [kgm ²]
100	7.5 – 15	100	250	140	218	18	75	187	8	209	18	5	190	M8	34	0.22
110	10 – 20	110	285	175	245	20	80	197	8	208	20	6	198	M8	38	0.31
120	13 – 26	120	285	175	245	20	60	215	8	237	20	6	220	M10	47	0.38
130	17 – 33	130	315	175	280	22	100	230	8	250	22	6	234	M8	60	0.60
140	20 – 40	140	350	220	310	22	110	235	10	261	25	7	243	M10	64	0.78
150	25 – 50	150	350	220	310	22	115	247	10	305	25	7	270	M10	78	0.97
160	35 – 71	160	390	250	345	24	120	275	10	355	28	7	320	M10	130	1.5
180	49 – 98	180	435	280	385	27	135	320	10	300	40	8	282	M10	150	2.9

The coupling is a tailor-made product. The table shows some examples. Other sizes and features are available upon request.

M_A : release torque – adjustment range

m: mass (weight)

J: mass moment of inertia

Dimensions in mm.

SafeSet SR-F

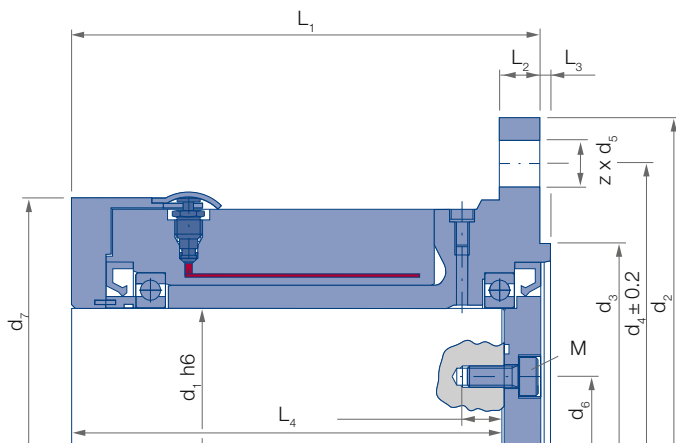

SR-F with membrane coupling

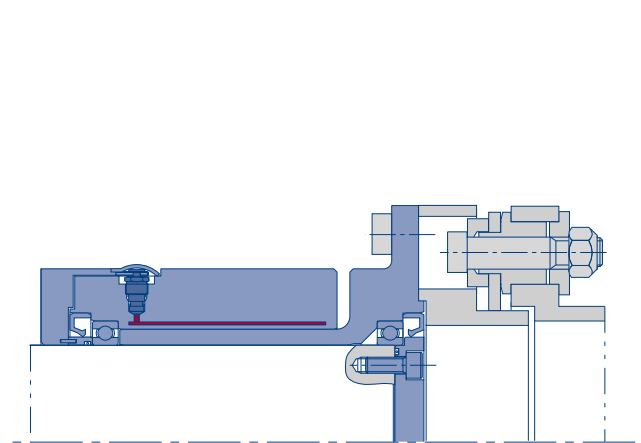

SR-F Series for Heavy Duty Shaft to Flange Connections

For installation between a plain shaft and a flange connection, such as universal joint shaft, elastic coupling, steel membrane coupling etc.

Size SR-F	M_A [kNm]	d_1	d_2	d_3	L_1	m [kg]
300	200 – 400	240	520	315	500	400
400	350 – 750	320	600	390	600	800
500	700 – 1400	400	750	550	750	1500
600	1000 – 2000	480	900	700	950	2200
710	1700 – 3500	570	1070	800	1150	3500
800	2500 – 5000	640	1200	880	1200	5000
900	3500 – 7000	720	1350	1020	1350	7000
1000	5000 – 10000	800	1500	1220	1500	10000

The coupling is a tailor-made product. The table shows some examples.

M_A : release torque – adjustment range

m: mass (weight)

Dimensions in mm.

SafeSet SR-F

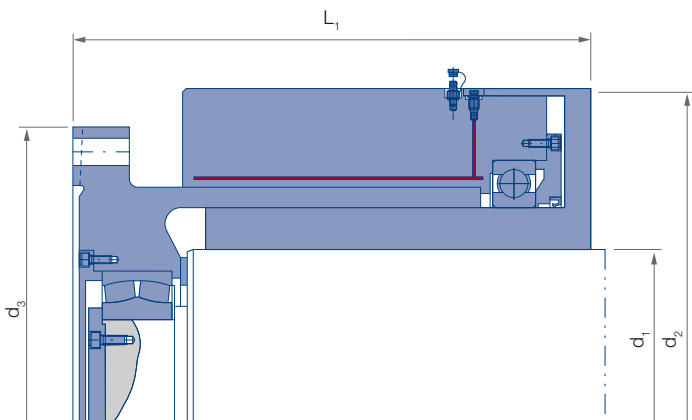

SR-F 1000 with universal joint shaft

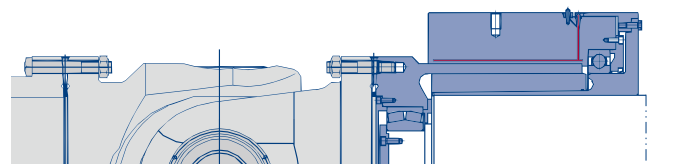

SR-C Series for Heavy Duty Compact Design

The SR-C series, has been specially designed for high torque applications, where the normal SR-F series coupling is simply too large for the available space. Can be designed as SR-NC – shaft to flange connection or SR-PC – flange to flange connection.

Size SR-PC	M_A [kNm]	d	L
520	750 – 1500	730	640
575	1000 – 2000	805	700
690	1750 – 3500	970	870
780	2500 – 5000	1090	1000
870	3500 – 7000	1220	1100
950	4500 – 9000	1325	1120

The coupling is a tailor-made product. The table shows some examples.
 M_A : release torque – adjustment range
 Dimensions in mm.

SR-PC series, integrated into a universal joint shaft

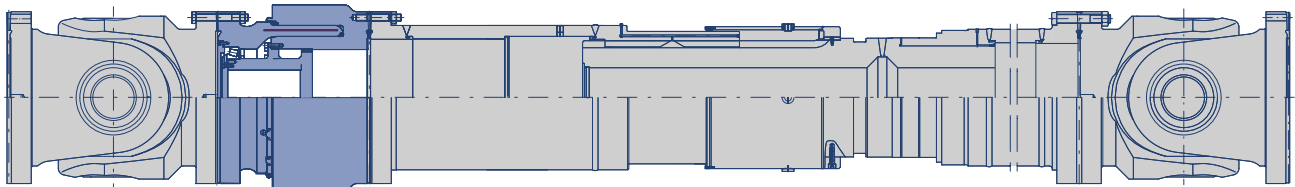

SafeSet SR-PC

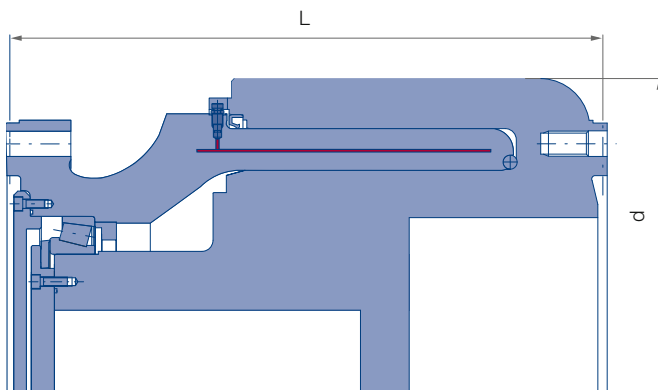

SR-NC with universal joint shaft

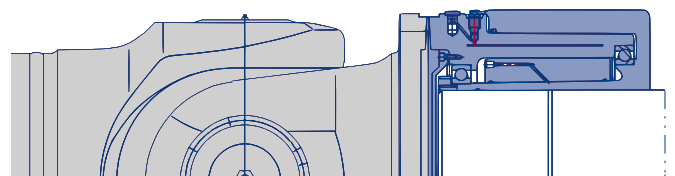

SR-F Series for Shaft to Flange Connections

The couplings are designed and manufactured to fulfill present DNV GL rules for marine applications. Protects sensitive drive-lines for thrusters, waterjets and conventional propulsion.



Size SR-F	M_A [kNm]	d_1	d_2	d_3	L_1	L_2	L_3	m [kg]	J [kgm ²]
100	9 – 18	100	175	235	16	242	222	34	0.19
110	12 – 24	110	187	260	18	267	252	41.5	0.27
120	16 – 32	120	199	285	20	287	271	50	0.38
130	20 – 41	130	210	305	22	305	289	58	0.50
140	26 – 52	140	227	325	23	322	306	71.5	0.72
150	32 – 65	150	242	345	26	341	325	85.5	0.98
160	40 – 79	160	258	365	27	359	343	102	1.32
170	46 – 93	170	277	390	29	388	370	128	1.90
180	56 – 112	180	292	415	31	407	389	150	2.5
190	65 – 131	190	309	435	32	427	409	175	3.3
200	77 – 155	200	324	455	34	441	423	198	4.1
220	105 – 210	220	355	495	38	472	454	254	6.3
240	139 – 278	240	386	525	41	523	501	326	9.3
260	176 – 352	260	417	575	44	560	537	410	13.8
280	222 – 444	280	448	605	47	600	577	499	19.2
300	265 – 530	300	486	635	51	646	622	634	28
320	323 – 646	320	516	695	54	685	660	763	38.6

The coupling is a tailor-made product. The table shows some examples. Other sizes and features are available upon request.
 M_A : release torque – adjustment range
 m: mass (weight)
 J: mass moment of inertia
 Dimensions in mm.

SafeSet SR-F

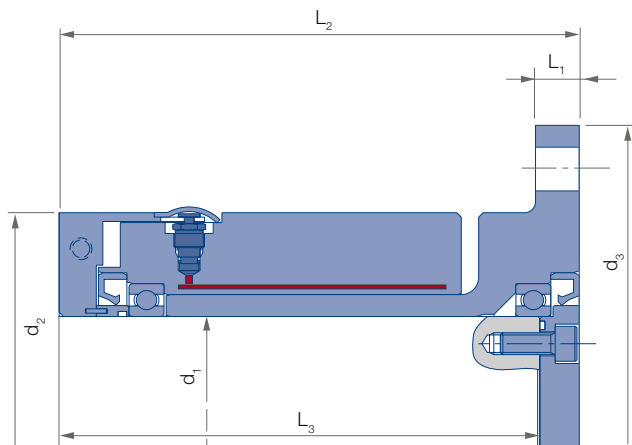

SR-F with membrane coupling

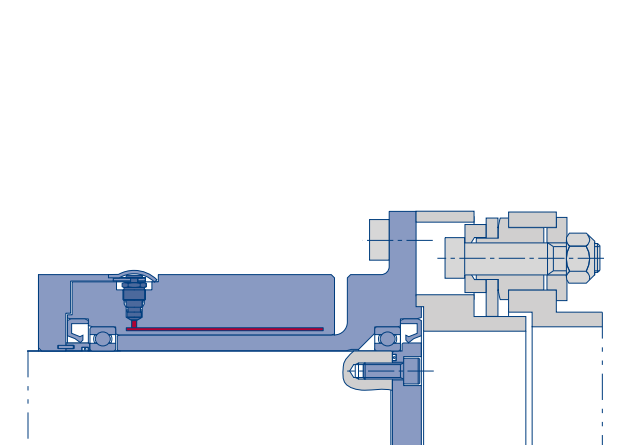

SR-PF Series for Flange to Flange Connections

The couplings are designed and manufactured to fulfill present DNV GL rules for marine applications. Protects sensitive drive-lines for thrusters, waterjets and conventional propulsion.



Size SR-PF	M_A [kNm]	d_1	d_2	L_1	L_2	m [kg]	J [kgm ²]
100	9 – 18	175	235	16	253	53	0.23
110	12 – 24	187	260	18	279	67	0.36
120	16 – 32	199	285	20	301	84	0.52
130	20 – 41	210	305	22	320	100	0.71
140	26 – 52	227	325	23	340	123	1.00
150	32 – 65	242	345	26	359	149	1.38
160	40 – 79	258	365	27	377	177	1.84
170	46 – 93	277	390	29	408	220	2.62
180	56 – 112	292	415	31	427	258	3.46
190	65 – 131	309	435	32	448	301	4.46
200	77 – 155	324	455	34	463	342	5.60
220	105 – 210	355	495	38	498	443	8.68
240	139 – 278	386	525	41	549	568	12.8
260	176 – 352	417	575	44	590	718	19.1
280	222 – 444	448	605	47	632	878	26.4
300	265 – 530	486	635	51	680	1095	37.6
320	323 – 646	516	695	54	721	1328	52.9

The coupling is a tailor-made product. The table shows some examples. Other sizes and features are available upon request.

M_A : release torque – adjustment range

m : mass (weight)

J : mass moment of inertia

Dimensions in mm.

SafeSet SR-PF

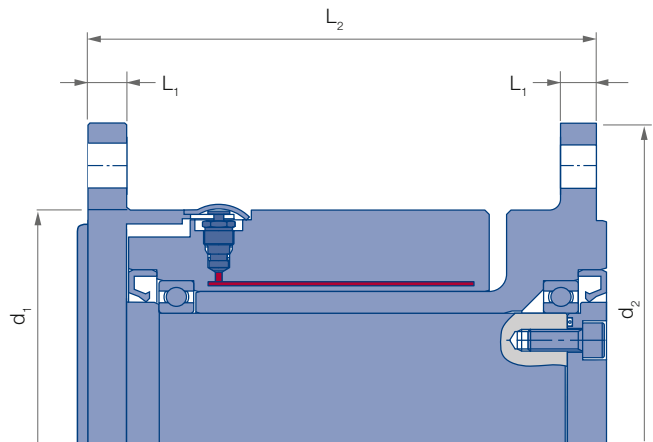

SR-PF with gear coupling and double flange design

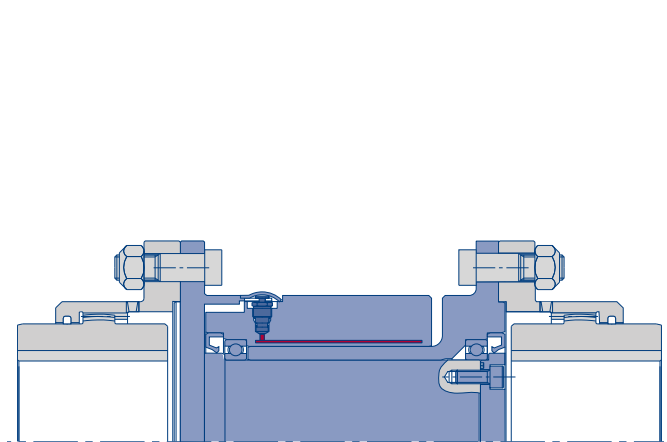

Special Adaptions

SR-F integrated with a slipper spindle

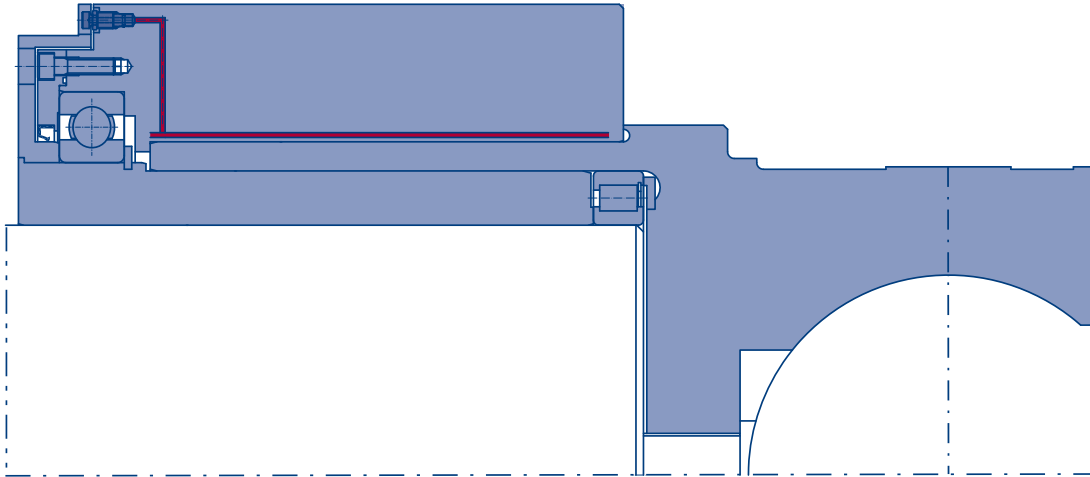

SR-F integrated with a gear spindle

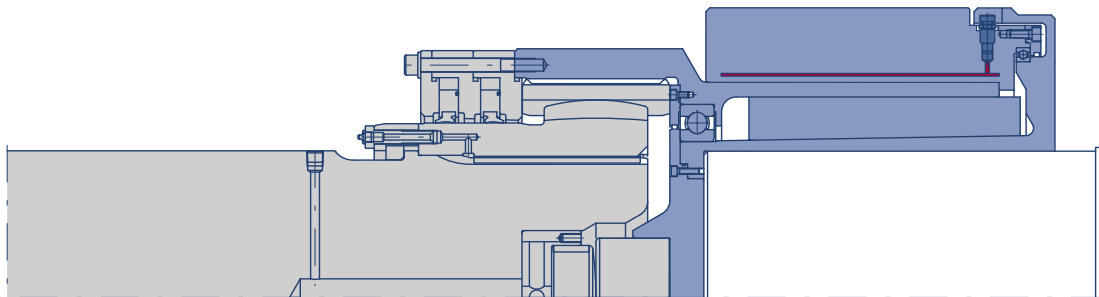

SR-N compact solution for limited space

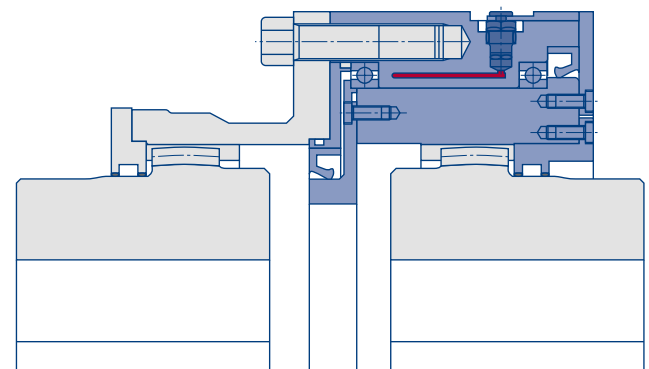

SR-P compact solution for limited space
to replace shearpin coupling

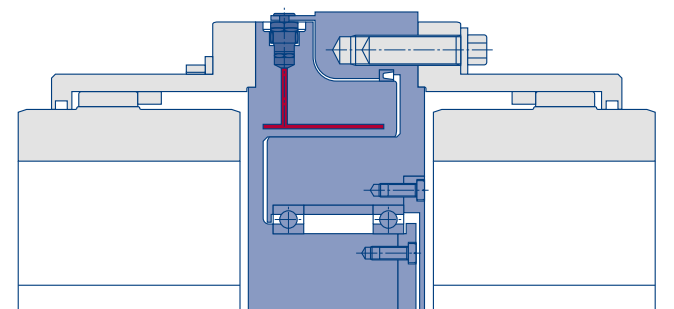

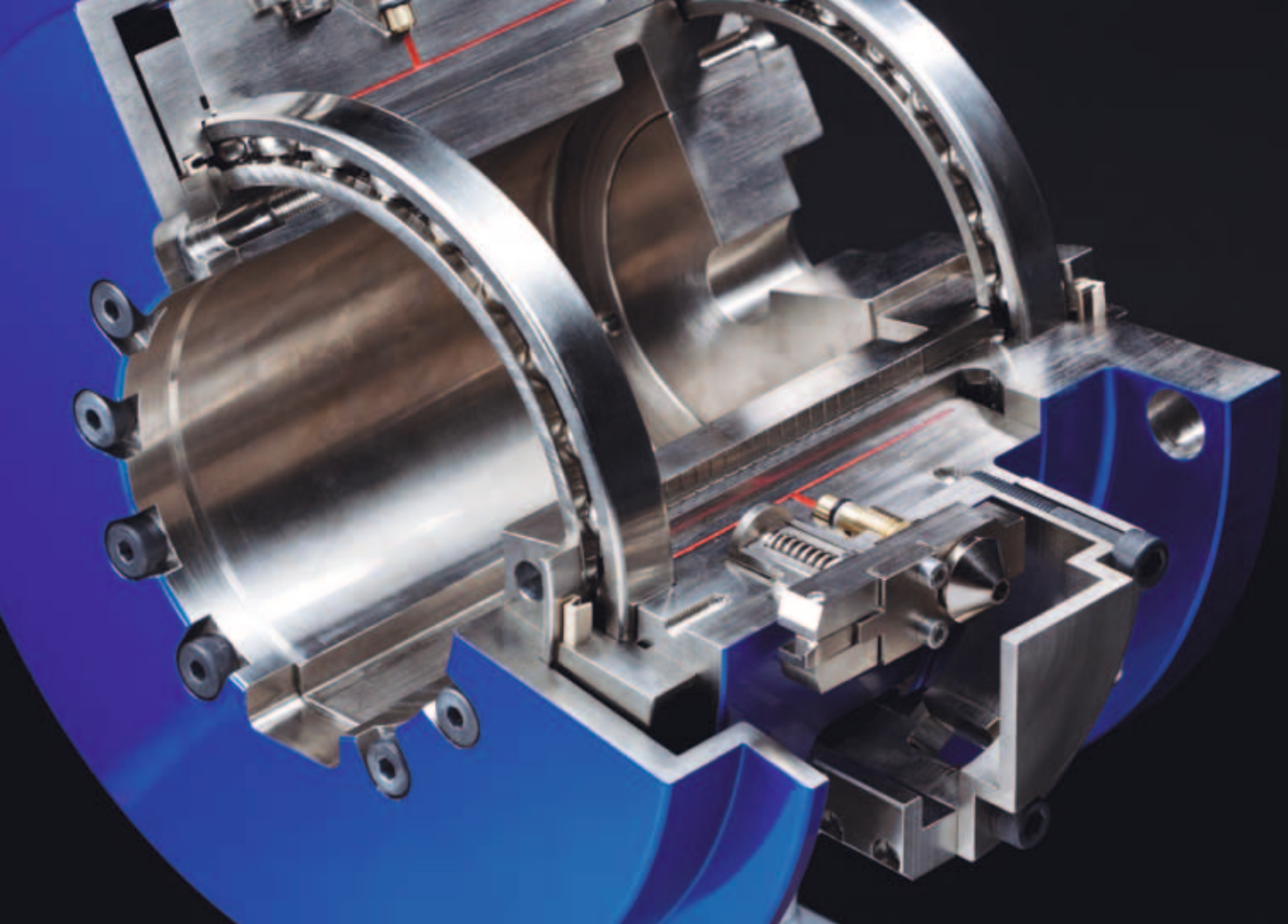

SmartSet – Process Improving Coupling with Controlled Slip

SmartSet is based on the same technology as the SafeSet coupling, but it is equipped with a SmartSet device that will give the coupling an additional slip feature. This centrifugal device is activated by the rotational speed of the intended application. This enables the coupling to slip during high transient torques, that are an inherent part of many applications with synchronous motors.

If the torque peak is of long duration in an overload situation, the SmartSet coupling can fully release as a normal SafeSet coupling and subsequently save the drive train from catastrophic failure.

Torque capacity available between 10 to 10 000 kNm.

SmartSet basic principle

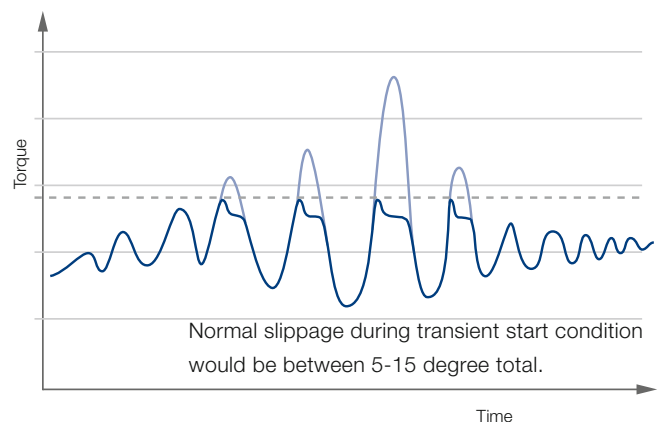

- SmartSet set torque limit
- Torque peaks without SmartSet
- Controlled slip torque curve

SM-F Series for Shaft to Flange Connections

Size SM-F	M_A [kNm]	d_1	L	d_2
280	68-135	190	313	530
300	100-200	220	363	560
320	150-300	250	414	585
360	200-400	280	452	640
400	265-530	300	463	695
460	355-710	310	491	770
500	475-950	350	544	840
560	630-1260	380	564	920
600	725-1450	390	690	995
650	913-1825	410	745	1060

The coupling is a tailor-made product. The table shows some examples. In order for the SmartSet function to be activated, the rotation speed needs to be >500rpm for all models in the table
 M_A : release torque – adjustment range
 Dimensions in mm.

SM-F

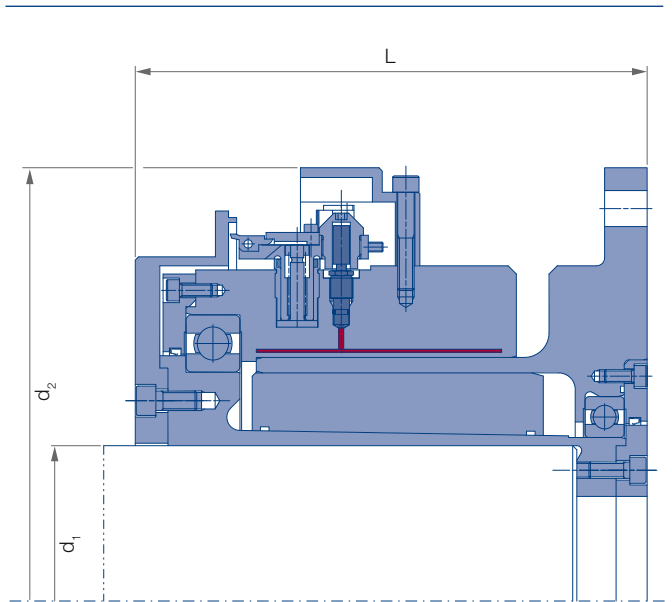

SM-PF Series for Flange to Flange Connections

Size SM-PF	M_A [kNm]	d_1	L	d_2
280	68-135	-	349	530
300	100-200	-	410	560
320	150-300	-	464	585
360	200-400	-	508	640
400	265-530	-	519	695
460	355-710	-	545	770
500	475-950	-	605	840
560	630-1260	-	625	920

The coupling is a tailor-made product. The table shows some examples. In order for the SmartSet function to be activated, the rotation speed needs to be >500rpm for all models in the table
 M_A : release torque – adjustment range
 Dimensions in mm.

SM-PF

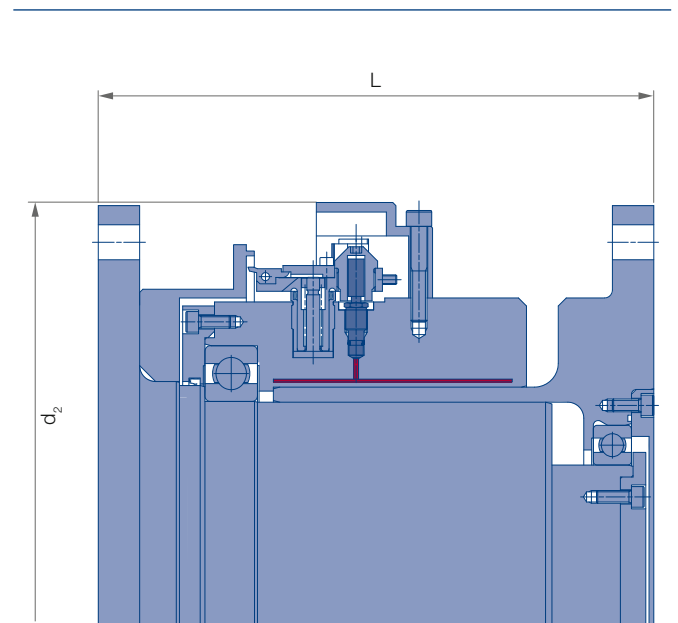



AutoSet – Process Improving Coupling with Controlled Slip and Automatic Reset

The AutoSet is a torque limiting coupling with a slip function and automatic reset to enhance performance. AutoSet reduces high torque peaks by slipping up to 180 degrees without releasing. If the torque peak has a longer duration the AutoSet will release entirely and limit the torque. It is completely automatic and the self-reset function maximizes production uptime.

The AutoSet friction grip is created by a hydraulically adjustable tapered sleeve that generates the preset torque level.

If the set torque is exceeded, the coupling slips and limits the torque with an accuracy of $\pm 10\%$ during standard performance.

After release the coupling automatically resets itself to the full preset torque level and no manual handling is needed. This avoids lengthy stoppages in production.

Torque capacity available between 0.41 to 275 kNm



Without AutoSet

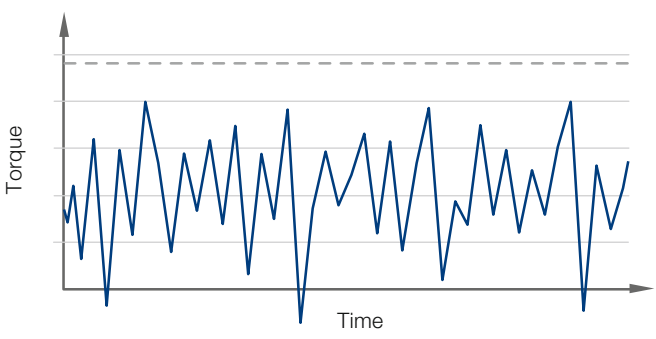

-- Release torque with a shear pin coupling
 — Torque peaks during production

With AutoSet

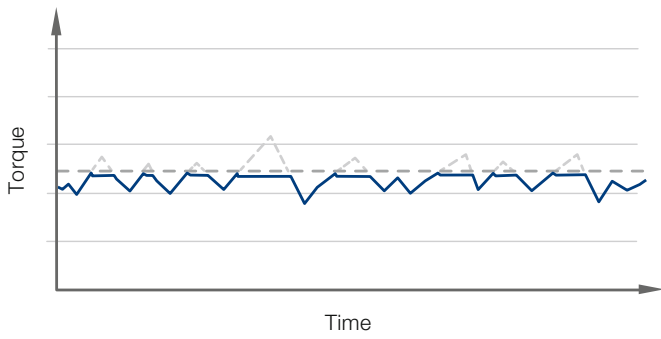

-- Release torque slip
 — Torque with AutoSet

Customized AutoSet for Shaft to Flange and Flange to Flange Connection

For larger outer diameter than 280 mm universal joints are normally used. In such cases AutoSet would be installed on the output shaft of the gearbox.

SA-P, flange to flange connection

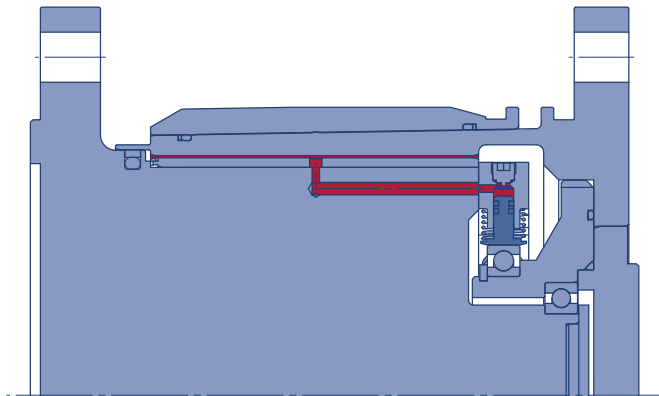

SA-F, shaft to flange connection, installed on the output shaft of the pinion gearbox

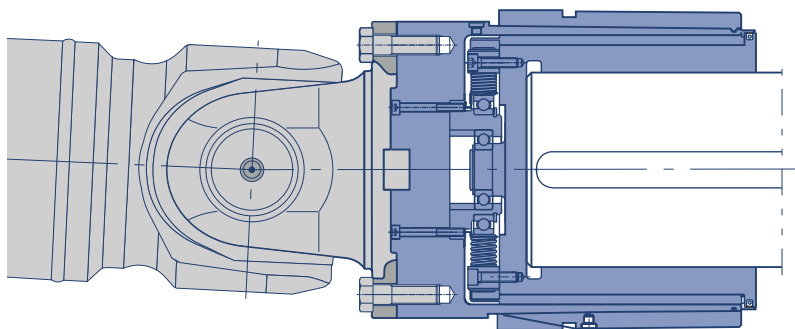

SA-I Series for Integrated Custom Solutions

The SA-I series integrates the AutoSet principle into the drive spindle itself, which is typically performed on gear spindles. The table below shows examples of the typical dimensions.

Size SA-I	M_A [kNm]	d	L	Max speed [rpm]
38	0.3 – 0.72	48	250	x 1000
45	0.8 – 1.6	60	260	x 850
57	1.2 – 2.5	76	270	x 670
73	3 – 7.4	98	310	x 520
95	6 – 12	119	350	x 400
120	12 – 24	155	450	x 320
130	16 – 33	175	470	x 290
150	22 – 45	200	530	x 250

The coupling is a tailor-made product. The table shows some examples.

M_A : release torque – adjustment range

Dimensions in mm.

SA-I with gear spindle

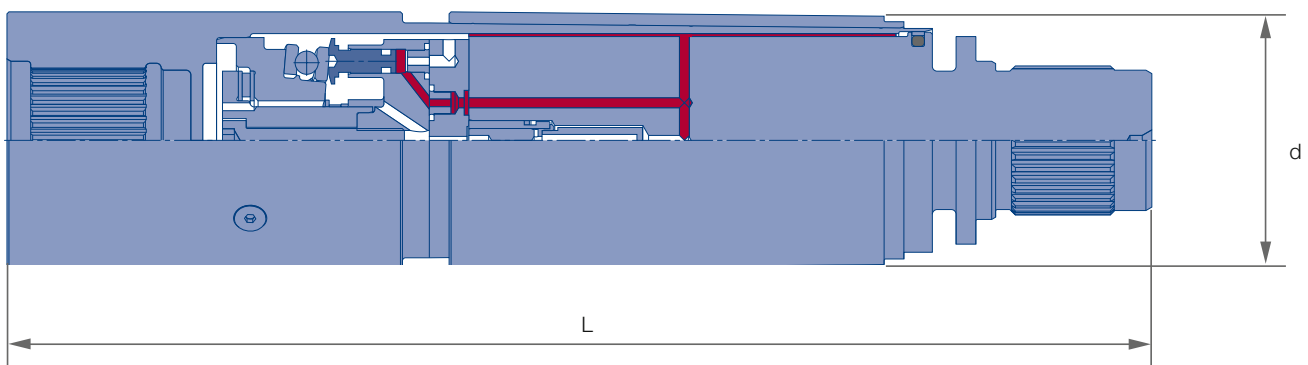

Equipment for Easy Handling

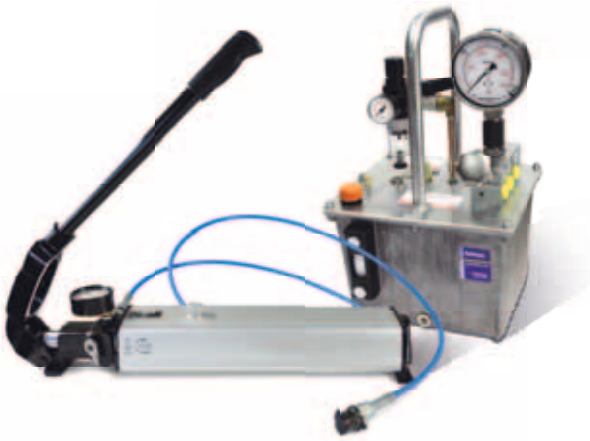

Pump P240 and P500

Pumps

For pressurizing your coupling, Voith offer a complete range of hydraulic pumps; from manual versions to powered variants. The size of the pump will be dependent on the size of the coupling to be pressurized.



Service box

Service boxes

Voith offer all the necessary tools and equipment needed to operate the couplings. Each service box is adapted for the specific type of coupling. Just a few of the equipment needed are, for example, torque wrenches, allen wrenches and plug pullers.

For demanding applications digital manometers are available. They ensure a more exact pressure setting and therefore provide a more precise release point.

Recommended pump sizes

Pump	Operation	Coupling size
P115	Manual	30-250
P240	Manual	150-350
P500	Pneumatic	300-600
P1000	Pneumatic	over 500

For special applications, electrically driven pumps or customized solutions are available upon request.
Dimensions in mm.



Shear tube

Shear tubes

Depending on the size of the coupling and its application, the coupling could have between 1 to 12 shear tubes of a suitable size installed.

Shear tubes with extended heads are also available (VK model) for couplings where external release capability is required such as engine test benches.

Shear tubes

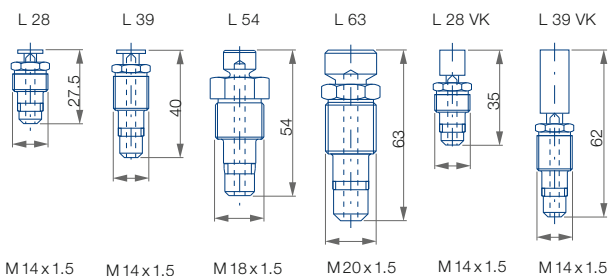

Release monitoring

Electronic release indicator

Torque limiting couplings can be equipped with an electronic release indicator, which indicates when the coupling has released.

By measuring the input and output speed with proximity sensors, the speed difference can be monitored. During a release the speeds will no longer be synchronous. The indicator recognizes this and triggers an alarm to warn the machine operators.

In cases where the speed differential can not be measured the coupling can be equipped with a mechanical visual release indicator.



Long Term Partnership and Support

Voith is a reliable partner for the entire service life of your driveline, offering a wide range of service and support, when and wherever you need it.

You can rely on us during every part of the process, from installation, to initial start-up and final commissioning. Our technicians ensure the trouble free start-up of your machine which also gives you the peace of mind that it has been correctly built in. Voith trains your personnel on how to operate the coupling, which optimizes performance and maintains constant reliability.

Regular health checks provide a high quality operation at a low expense and minimize costly production downtimes. Proactive maintenance of torque limiting couplings increases the service life, improves performance and reduces lifecycle costs, to ensure maximum return on your investment.

Voith has regional service centers worldwide. We are here to support you 24 hours a day, 7 days a week. Thanks to our global network, we are always nearby.



- 1 Friction surface inspection
- 2 Installation
- 3 Engineers and designers

Voith – Engineered Reliability

Voith sets standards in the energy, oil & gas, paper, raw materials and transportation & automotive markets. Founded in 1867, Voith employs more than 43 000 people, generates €5.7 billion in sales, operates in over 50 countries around the world and is today one of the largest family-owned companies in Europe.

Voith Turbo, a Group Division of Voith GmbH, is a specialist for intelligent drive solutions and systems. Customers from highly diverse industries such as oil & gas, energy, mining & mechanical engineering, ship technology, rail & commercial vehicles rely on advanced technologies from Voith Turbo.

Voith Turbo Safeset are the experts in developing and manufacturing torque limiting, process improving and connection couplings within Voith.

The company in Sweden supplies customers worldwide with the most reliable systems available. With over 30 years of experience, Voith Turbo Safeset has unique knowledge in their field. Combining engineering skills, innovative strength and a solid base, Voith Turbo SafeSet is a partner to rely on for generations to come.

Voith Turbo SafeSet AB
Rönningevägen 8
82434 Hudiksvall, Sweden
Tel. +46 650 540150
Fax +46 650 540165
info.safeset@voith.com
voith.se/hudiksvall

VOITH
Engineered Reliability